

1 Fix arm (**K**) to the wall using accessories (**H**) and (**I**). See warning 1. If fixing to wood, wall plugs (**H**) not required. Ensure bracket is perfectly straight using spirit level if required.

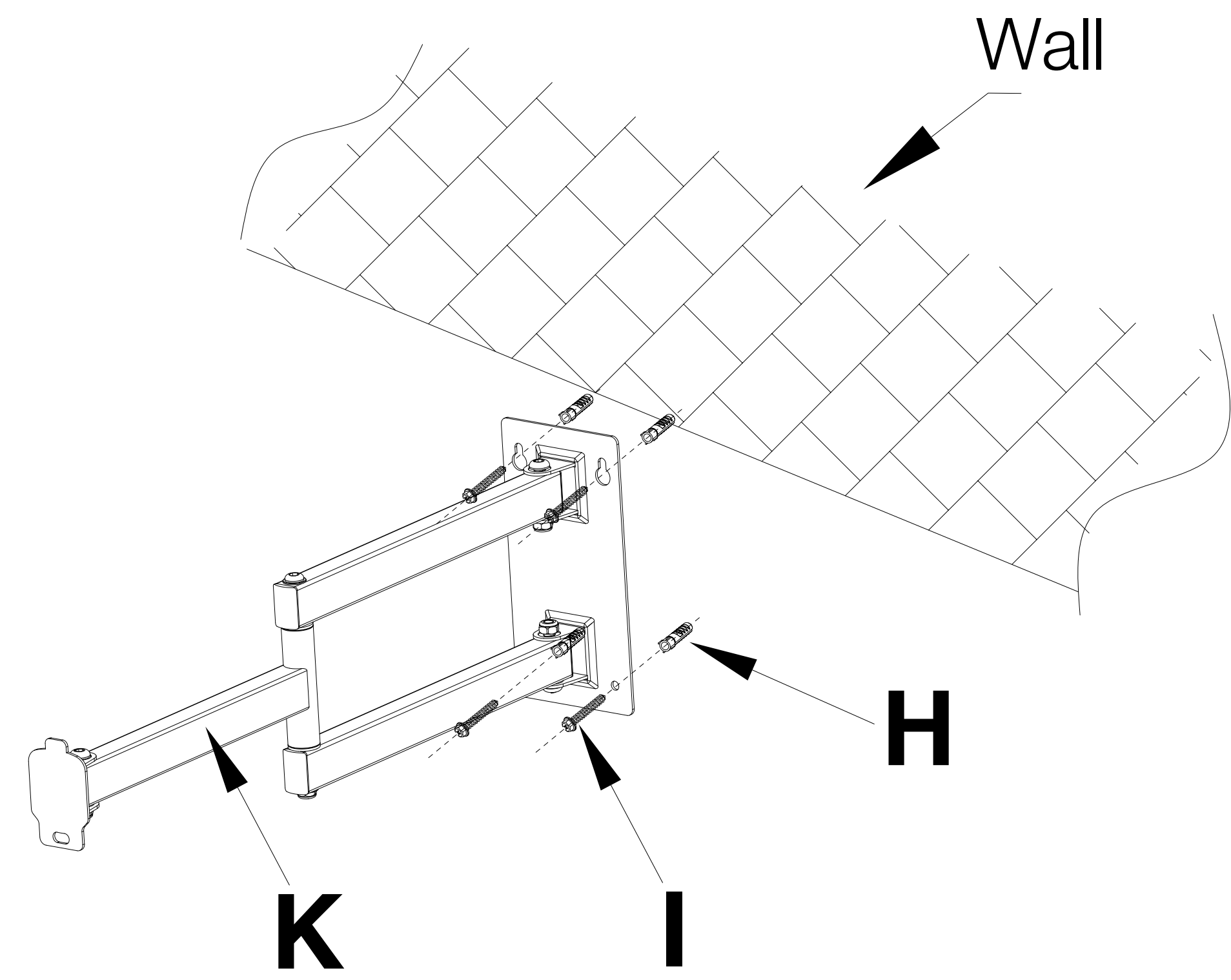

2 Fix both brackets (**J**) to mount (**L**), using M8 x 8 screws (**G**).

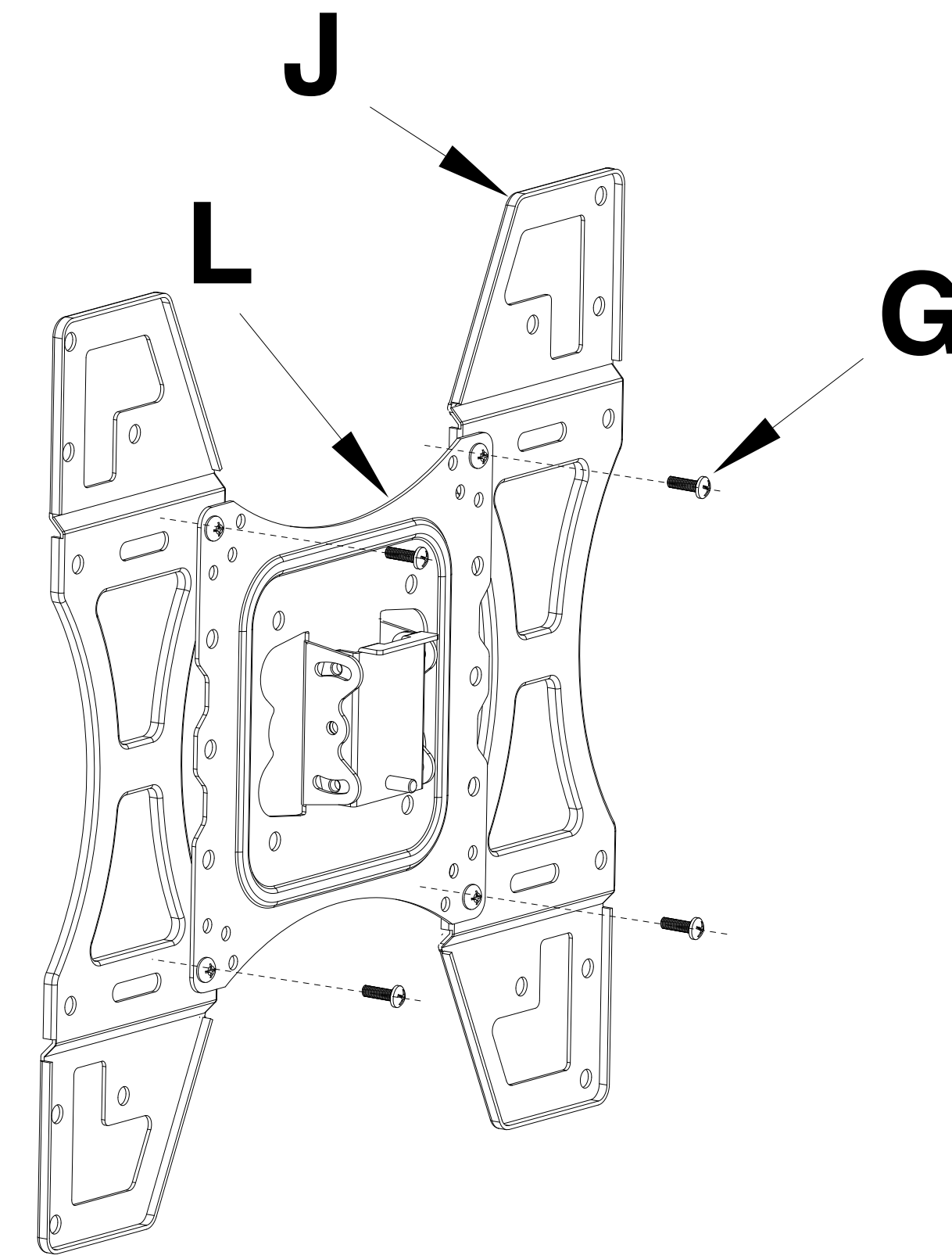

3 Fix assembled plate to back of TV using correct screws (**A / B / C**). Use washers (**D / E / F**) with smaller screws.

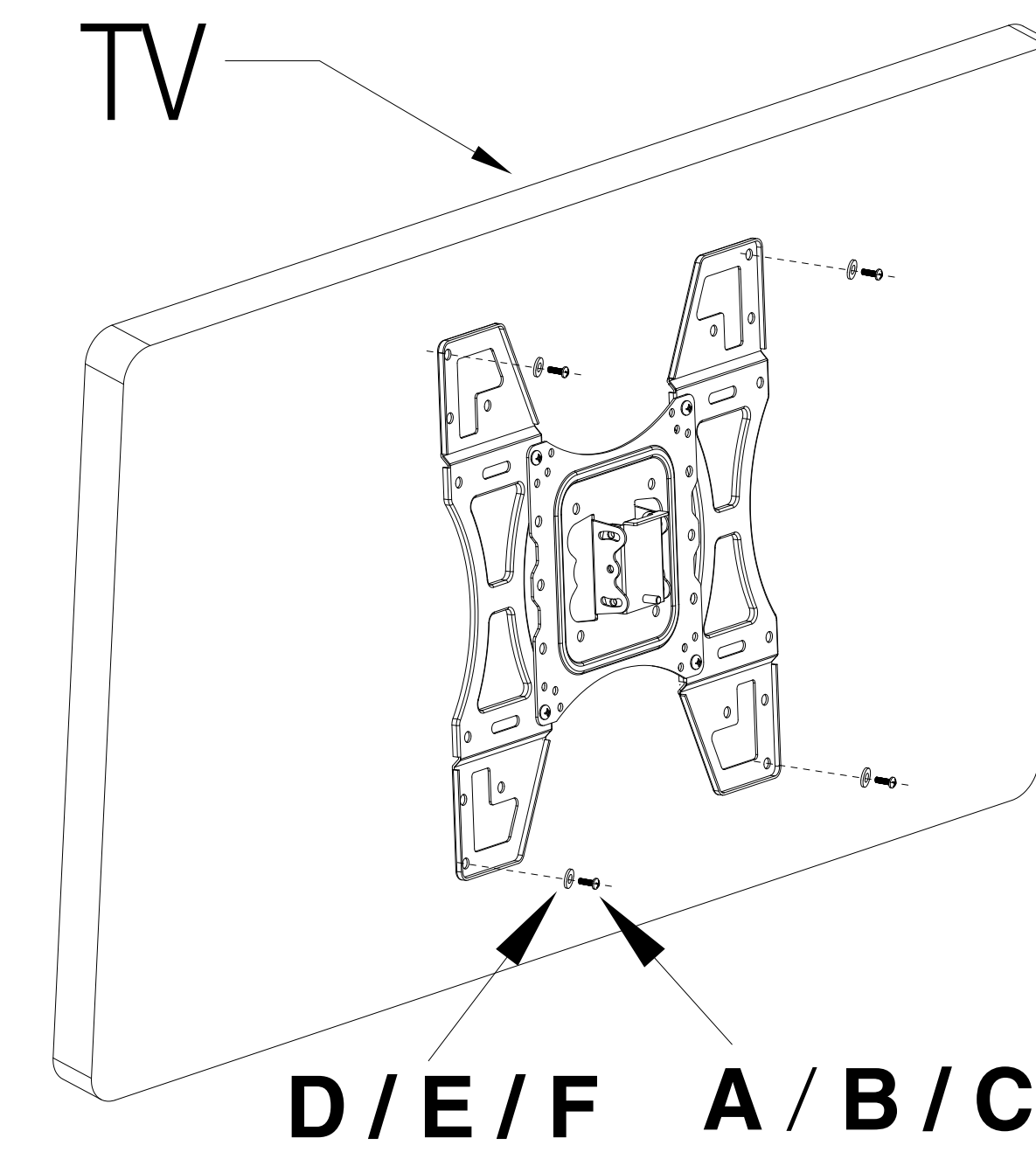

4 Slip TV onto wall arm (**K**) as shown. Fasten nut to stud and tighten to secure.

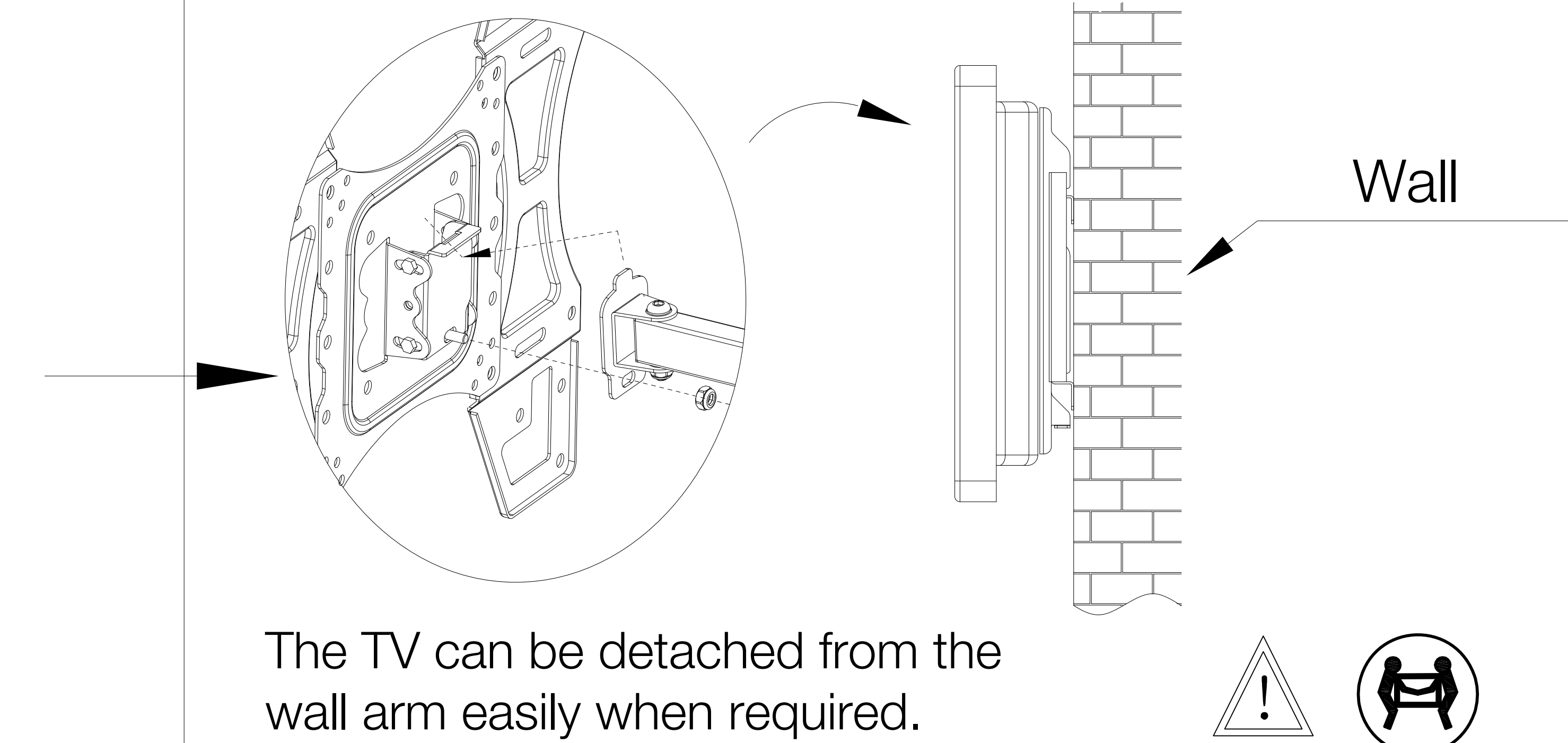

The TV can be detached from the wall arm easily when required.

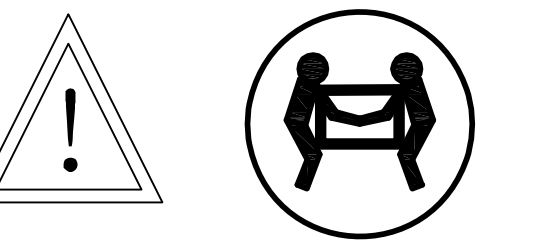

Do not attempt to lift the TV by yourself.

! WARNING :

1. The plate must be installed on a firm surface such as a wall made from concrete, solid brick or solid wood.
2. Tighten the screws so that the wall plate is firmly attached, but do not over-tighten. Over-tightening can damage the screws, greatly reducing their ability to hold.
3. Do not remove or loosen screws unless the TV is removed. Doing so may cause the bracket to fall.
4. This product should be installed by a qualified tradesman.

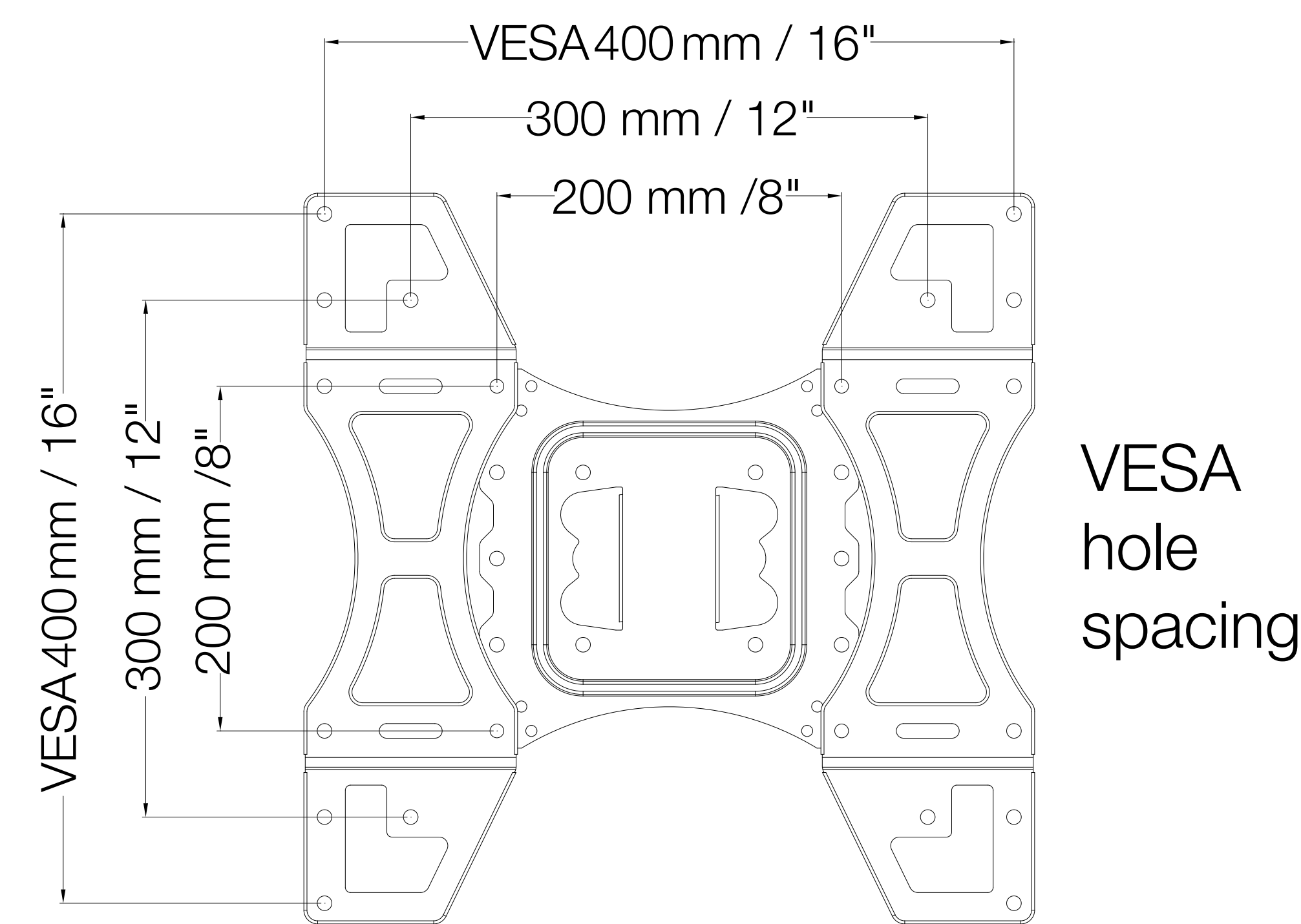

VESA hole spacing : 400 x 400 mm
300 x 300 mm
200 x 200 mm
100 x 100 mm

For TV sizes : 22 to 50 inch
Maximum load : 30 kg

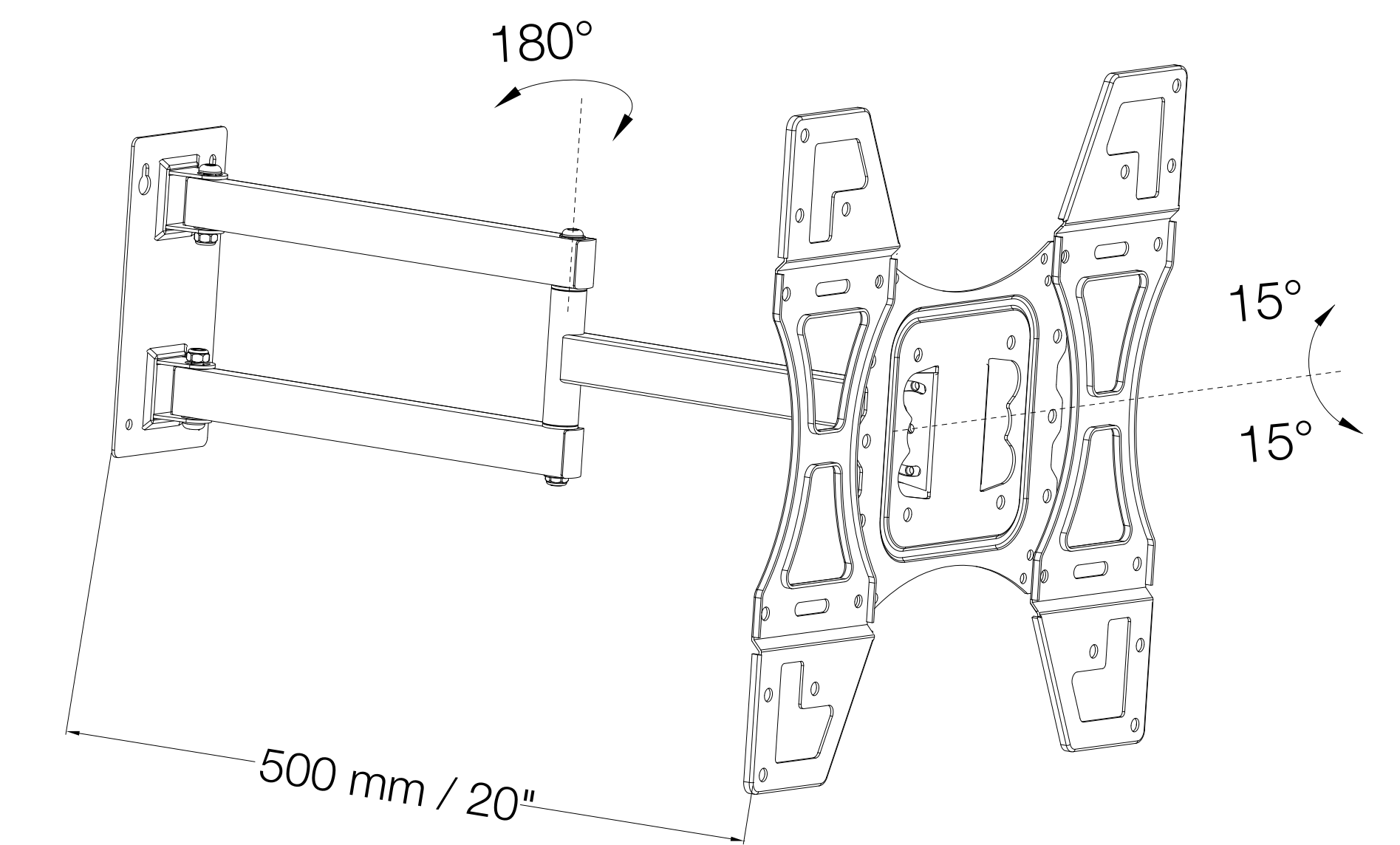

PARTS

- A** M8 x 15 (4 pcs)
- B** M6 x 15 (4 pcs)
- C** M5 x 15 (4 pcs)
- D** Ø8 (4 pcs)
- E** Ø6 (4 pcs)
- F** Ø5 (4 pcs)

- G** M8 x 8 (4 pcs)
- H** Ø10 x 50 (4 pcs)
- I** M6 x 50 (4 pcs)
- J** (2 pcs)
- K** (1 pc)
- L** (1 pc)