

- 1** Fix bracket (I) to the wall with (G) and (H). See warning 1. Wall plugs (G) not required if fixing to wood. Use a spirit level to achieve correct level.

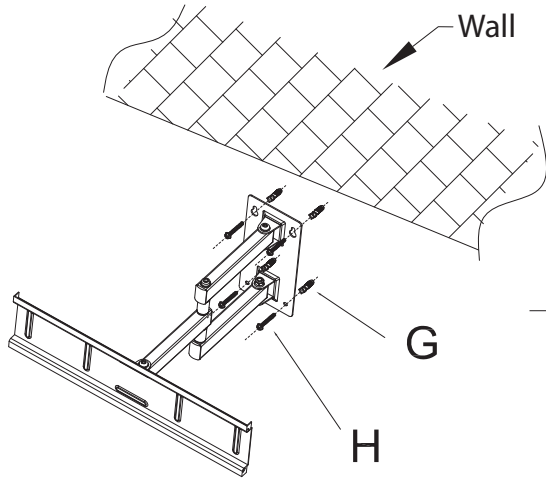

- 2** Fix the vertical brackets (J) to the back of your TV using screws (A, B or C) as required, with appropriate washers (D, E or F). Some TVs may require the use of your own screws.

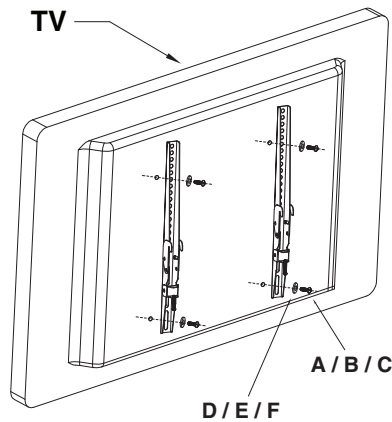

- 3** Hang the TV on the wall plate and tighten the screw to avoid lateral movement.

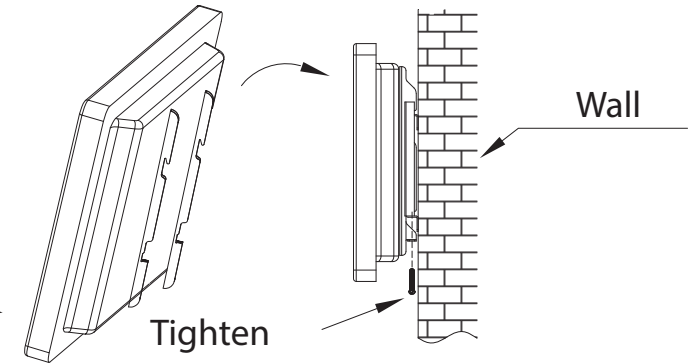

Do not attempt to lift the TV by yourself.



WARNING :

- The plate must be installed on a firm surface such as a wall made from concrete, solid brick or solid wood.
- Tighten the screws so that the wall plate is firmly attached, but do not over-tighten. Over-tightening can damage the screws, greatly reducing their ability to hold.
- Do not remove or loosen screws unless the TV is removed. Doing so may cause the bracket to fall.
- This product should be installed by a qualified tradesman.

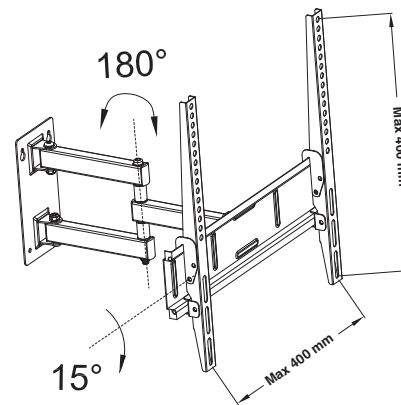

Maximum VESA hole spacing : 400 x 400 mm
For TV sizes : 32 inch and up
Maximum load : 35 kg

PARTS

A	M8 x 15 (4 pcs)	F	ø5 (4 pcs)
B	M6 x 15 (4 pcs)	G	ø10 x 50 (4 pcs)
C	M5 x 15 (4 pcs)	H	M6 x 50 (4 pcs)
D	ø8 (4 pcs)	I	(1 pc)
E	ø6 (4 pcs)	J	(2 pcs)